



*Integra 1540 provides programmable measurement, display and communication of up to 31 major electrical and power quality parameters, including true RMS system values, total harmonic distortion (THD) measurement and power quality data. The meter offers simple user-friendly programming of voltage, current, and power measurement parameters using a menu driven interface. Status of all parameters can be viewed through 13 screens on the 3 line, 4 digit LED display. The Integra 1540 has pulsed and digital communication outputs and is ideal for all power and quality monitoring applications.*

## Features

- Measurement, display and communication of up to 31 power parameters
- THD measurement and power quality data
- True RMS measurement
- Pulsed energy outputs
- Digital communications
- Fully programmable VT and CT ratios
- Simple menu driven interface
- ANSI case style
- High quality LED display

## Benefits

- Replaces multiple single function instruments
- Simple menu driven interface
- Remote monitoring
- Monitoring, control and protection of power assets

## Applications

- Switchgear
- Distribution systems
- Generator sets
- Control panels
- Energy management
- Building management
- Utility power monitoring
- Process control
- Motor monitoring

## Approvals

- UL File No: 140758
- IEC 1010 / BSEN 61010-1

## Operation

A two button interface on the front panel of Integra 1540 units provides simple programming of VT and CT ratio settings, configuration of selected communication options, and adjustment of operating parameters. To prevent unauthorised access to the product configuration settings, all set up screens offer password protection. Once configured, status information can be viewed by scrolling through 13 screens featuring a high contrast 3 line, 4 digit LED display, with separate annunciators for each of the 31 measured parameters. Optional pulsed or digital outputs allow status information to be communicated into building management systems.

## System Input

Designed for all low, medium and high voltage switchgear and distribution systems, the Integra 1540 has customer programmable VT and CT ratio capability. Direct connected up to 600V AC with 5A CT inputs as standard, and 1A CT inputs available as an option.

## Pulsed Outputs

Integra 1540 offers an optional pulse output module enabling the retransmission of time based demand parameters. Outputs are pulsed at a rate proportional to the measured kWh active energy, with pulse width and rate easily programmable via the set-up screens. The output relay has a fully isolated volt free contact, with connection via screw clamp terminals.

## Digital Communications

### RS485 Modbus RTU

Integra 1540 digital metering systems offer an RS485 communication port for direct connection to SCADA systems using the Modbus RTU protocol, or the Johnson Controls Metasys NII protocol. Remote monitoring enables the user to record the systems parameters in real time, using high resolution numbers. The Modbus protocol establishes the format for the master's query by placing it into the device address. The slave's response is also constructed using the Modbus protocol; it contains the fields confirming the action taken, the data to be returned, and an error-checking field. The Modbus option includes the ability to change Modbus word order to suit the requirements of the user.



## Measurement, Display and Communication

Integra 1540 offers configuration, display and communication of up to 31 electrical and power quality parameters.

1. System Volts  
System Current  
System kW
2. System Volts THD %  
System Current THD %
3. Volts L1 – N  
Volts L2 – N  
Volts L3 – N
4. Volts L1 – L2  
Volts L2 – L3  
Volts L3 – L1
5. Volts Line 1 THD %  
Volts Line 2 THD %  
Volts Line 3 THD %
6. Current L1  
Current L2  
Current L3
7. Current Line 1 THD %  
Current Line 2 THD %  
Current Line 3 THD %
8. Neutral Current  
Frequency  
Power Factor
9. kVA<sub>r</sub>  
kVA  
kW
10. kWh (7 digit resolution)
11. kVA<sub>r</sub> Hr (7 digit resolution)
12. kW Demand  
Current Demand
13. kW Maximum Demand  
Current Maximum Demand

## Programmable Parameters

Parameter	Range
Password	4 digit 0000 - 9999
Primary Current	Max 9999:5 (360MW max <sup>**</sup> )
VT Primary	400kV (360MW max <sup>**</sup> )
	<sup>**</sup> maximum VT or CT ratios are limited so that the combination of primary voltage and current do not exceed 360MW at 120% of relevant inputs
Demand Integration Time	8, 15, 20, 30 minutes
Reset	Max demand & active energy registers
Pulse Output Duration	60, 100, 200 ms
Pulse Rate Divisors	1, 10, 100, 1000
RS 485 Interface Baud Rate	2.4, 4.8, 9.6, 19.2 kB
RS 485 Parity	Odd / Even / No, 1 or 2 stop bits
Modbus Address	1 - 247

## Product Codes

Product Code	Product Configuration
INT-1544-***-5-* <sup>-option</sup>	Integra 1540 3 phase 4 wire 5A CT input
INT-1543-***-5-* <sup>-option</sup>	Integra 1540 3 phase 3 wire 5A CT input
<b>Input Voltage Suffix ***</b>	
100	100V L-L (57.7V L-N)
110	110V L-L (63.5V L-N)
115	115V L-L (66.4V L-N)
120	120V L-L (69.3V L-N)
139	139V L-L (80.2V L-N)
208	208V L-L (120V L-N)
240	240V L-L (139V L-N)
277	277V L-L (160V L-N)
380	380V L-L (220V L-N)
400	400V L-L (230V L-N)
415	415V L-L (240V L-N)
480	480V L-L (277V L-N)
600	600V L-L (346V L-N)
<b>Auxiliary Voltage Suffix*</b>	
L	12 – 48V DC
M	100 - 250V AC/DC
<b>Communications Options</b>	
M	RS485 Modbus RTU or Johnson Controls Metasys NII
W	kWh Pulsed output

## Order Code Example:

### INT-1544-120-5-L-W

Integra 1540 3 phase 4 wire, 120V L-L (69.3 L-N) nominal voltage, 5A CT input, 12-48V DC auxiliary supply, with pulsed output option.



\*\* maximum VT or CT ratios are limited so that the combination of primary voltage and current do not exceed 360MW at 120% of relevant input

## Specification

<b>Input</b>	
Nominal Input Voltage:	57.7 to 346V L-N, 100 to 600V L-L
Max Continuous Input Voltage:	120% nominal
Max Short Duration Input Voltage:	2 x for 1 second, repeated 10 times at 10 second intervals
System VT Ratios (primary):	400kV or 360MW **
Nominal Input Voltage Burden:	< 0.2 VA
Nominal Input Current:	5A (1A option)
System CT Primary Values:	9999:5A or 9999:1A max 360MW **
Max Continuous Input Current:	120% nominal
Max Short Duration Current Input:	20 x for 1 second, repeated 5 times at 5 second intervals
Nominal Input Current Burden:	< 0.6 VA
<b>Outputs</b>	
RS485 Communications:	Two wire half duplex
Baud Rates:	2400, 4800, 9600, 19200
Pulsed:	Clean contact SPNO, 100V DC 0.5A max
Pulse Duration:	60, 100 or 200 milliseconds
<b>Auxiliary</b>	
Standard Nominal Supply Voltage:	100 V – 250 V AC or DC (85 V – 287 V AC Absolute) (85 V – 312 V DC Absolute)
AC Supply Frequency Range:	45 – 66 Hz
AC Supply Burden:	6VA
Optional Auxiliary DC Supply:	12 V - 48 V DC (10.2 V – 60 V DC Absolute)
DC Supply Burden:	6VA
<b>Measuring Ranges</b>	
Voltage:	50 .. 120% of nominal (functional 5..120%)
Current:	5 .. 120% of nominal (50%..120% for THD)
Frequency:	45 .. 66Hz
Power Factor:	0.5 inductive – 1 – 0.8 capacitive
THD:	To 15th Harmonic V & A
Energy:	7 digit resolution
<b>Accuracy</b>	
Voltage:	±0.1% of range ±0.4% of reading
Current:	±0.1% of range ±0.4% of reading
Power:	±0.1% of range ±0.9% of reading
THD:	±1%
Neutral Current:	±4% of range
Energy:	kWh 1% IEC1036 (PF 0.8-1-0.8)
KVArh:	2% IEC1036 (PF 0.8-1-0.8)
Temperature Coefficient:	0.013%/°C typical
Update Time:	500ms display 250ms optional digital port
<b>Enclosure</b>	
Enclosure Style:	ANSI C39.1
Compliant With:	UL 140758 and IEC 1010 / BSEN 61010-1
Material:	Polycarbonate front and base, steel case
Terminals:	Barrier terminal strip 6-32 binding head screw
Dielectric Voltage:	Withstand test 3.25kV RMS 50Hz for 1 minute between all electrical circuits
Operating Temperature:	-20 to +70°C
Storage Temperature:	-30 to +80°C
Relative Humidity:	0 .. 95% non condensing
Warm-up Time:	1 minute
Shock:	30g in 3 planes
Vibration:	10 .. 15Hz, 1.5mm peak to peak / 15 .. 150Hz @1g
Enclosure Integrity :	IP54 (front face)
Dimensions:	4.31" high x 4.31" wide x 6.7" deep 109.4mm high x 109.4mm wide x 170.2mm deep
Panel Cut Out:	4.06" (103mm) diameter, 4 stud positions



**Integra 1540**



**Integra 0640**



**Integra 0440**



**Integra 0340**

## Dimensions

**Integra 1540, 1000, 0640, 0440 and 0340**

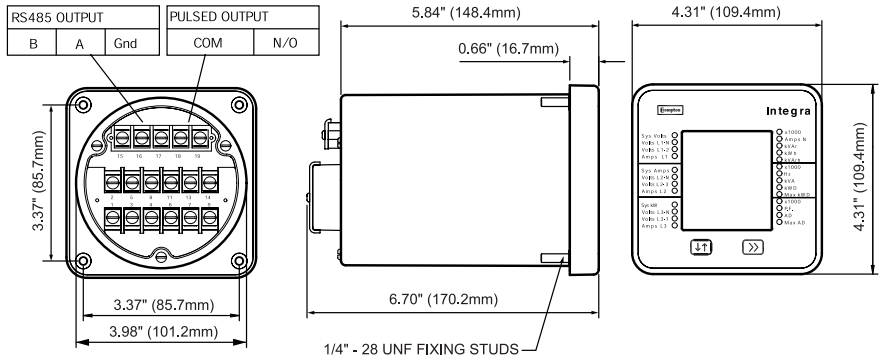

## Panel Cut Out

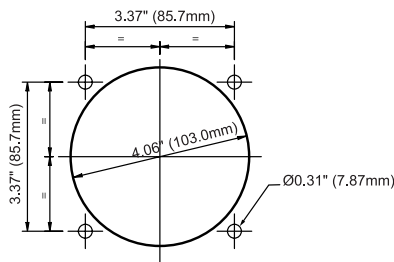

## Wiring

Input connections are made to screw clamp terminals. Terminals for both current and voltage connections are sized to accept two #9 AWG (3mm<sup>2</sup>) solid or stranded wires, or ring lugs suitable for 6-32 screws. Connections for communications and pulse outputs use identical style terminals.

### 3 phase 3 wire unbalanced load

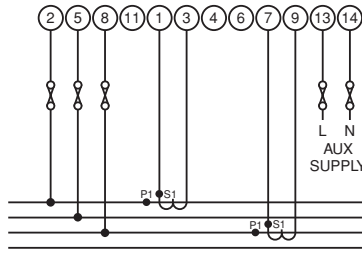

### 3 phase 4 wire unbalanced load

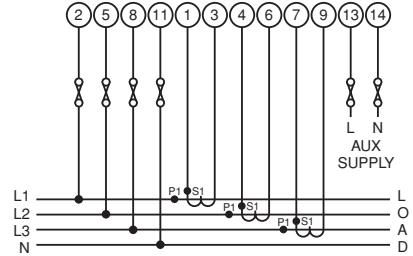

## Auxiliary Supply

The Integra family should ideally be powered from a dedicated supply, either 100 – 250V AC or DC (85V – 280V AC Absolute or 85V – 312V DC Absolute) or 12-48V DC (10.2V – 60V DC Absolute). However the device may be powered from the signal source, provided the source remains within the working range of the chosen auxiliary supply.

## Fusing

It is recommended that all voltage lines be fitted with 1 Amp fuses.

## Safety / Ground Connections

For safety reasons all CT secondary connections should be grounded in accordance with local regulations.